

# VELAN Universal Bimetallic Steam Traps

## Industry Proven for over 50 Years

Velan is one of the world's largest manufacturers of industrial steel valves, internationally recognized as a leader in quality and innovation. Since 1950, Velan has designed and manufactured valves for low emissions, easy maintenance and long, reliable service life. Today, Velan gate, globe, check, ball, butterfly and engineered severe service valves are installed throughout the world, delivering high performance in a diverse range of industrial applications.

Our comprehensive range of steam traps was developed and patented in 1956 by A.K. Velan, Founder and CEO of Velan Inc. Velan's high quality bimetallic steam trap design provides market-leading performance for high pressure steam trapping on superheated steam lines in thermal power plants and aboard ships – over 1,100 US Navy ships have used Velan steam traps.

### Velan Type N Steam Trap

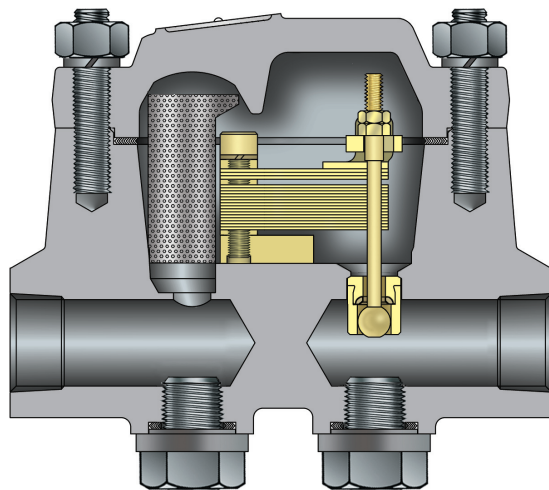

**For High Pressure Saturated and Superheated Steam Systems in Power Station & Marine Service**



#### Velan Type N Steam Trap Applications

- Main Steam Drains
- Hot Reheat Drains
- Cold Reheat Drains
- Turbine Extraction Drains
- Sootblower Drains
- Desuperheater Drains

### Unique Features

#### Velan Stellited Seats

Velan is the only steam trap manufacturer in the world to use Stellite in their valve seats.

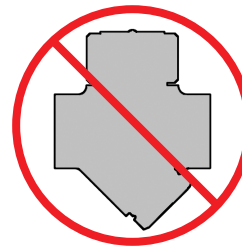
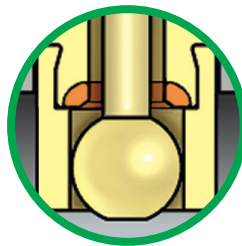

#### No Live Steam Wasted

Unlike thermodynamic or impulse traps Velan's unique bimetallic design doesn't waste live steam. Lower condenser temperatures mean a better heat rate for thermal power plants.

#### Unaffected by Waterhammer

The Velan design is impervious to waterhammer. Waterhammer will not damage the internal components.



#### Unaffected by Loss of Prime

Unlike inverted bucket steam traps, Velan's unique design remains shut tight in the presence of superheated steam.

To find your nearest Velan Steam Trap distributor, please email: [sales@velansteamtraps.com](mailto:sales@velansteamtraps.com) or call 1-800-860-0233

To learn more about Velan steam traps, visit us at [www.velansteamtraps.com](http://www.velansteamtraps.com)

# A Unique Method in Steam Trap Piping

**Velan Forged Piping King Automatic Condensate Drain Units provide substantial savings, in component parts & installation costs**

The Piping King Package unit fitted with a bypass, enables the steam trap to be isolated from the system allowing routine maintenance to be carried out.

**THE UNIT CONSISTS OF:**

- The unique patented Universal Steam Trap with integral strainer and check valve
- Two high-quality bonnetless forged steel special stop check globe valves mounted on either side of the trap.

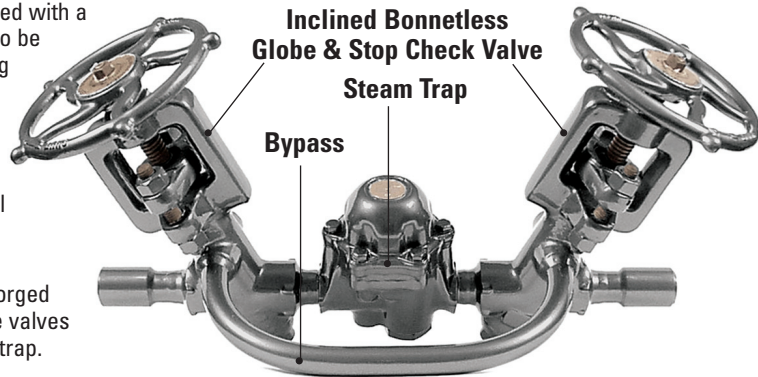

The valves are connected by the bypass pipe, enabling the steam trap to be isolated while the steam flow is maintained.

Piping King units are used extensively in the Power and Marine Industries, on high pressure/high temperature applications, where continuous operation is essential during routine maintenance.

## - Velan Piping Kings - SAVE OVER 30% ON A TYPICAL INSTALLATION

### CONVENTIONAL UNIT

with Bypass (3 Valves) & Bucket Trap

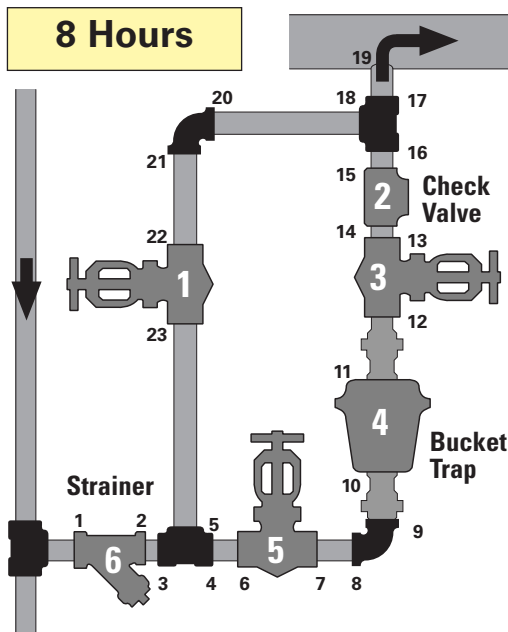

**6 Units - 23 Welds**

- |   |  |
|---|--|
| 1 Steel Bucket Steam Trap <sup>3/4"</sup> | 2 Elbows <sup>3/4"</sup> (s.w.)                  |
| 3 Forged Steel Valves                     | 3 Tees <sup>3/4"</sup> (s.w.)                    |
| 1 Steel Strainer <sup>3/4"</sup>          | 2 Unions <sup>3/4"</sup> - fitting time (2 hrs.) |
| 1 Steel Check Valve <sup>3/4"</sup>       | 23 Welded Joints (6 hrs.)                        |

### VELAN PIPING KING UNIT

with Bypass (2 valves only)

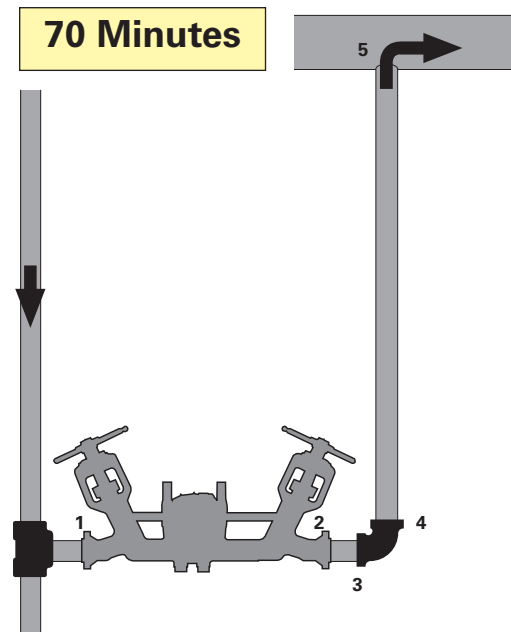

**1 Unit - 5 Welds**

- |  |
|--|
| 1 Velan Piping King <sup>3/4"</sup> Type NV-BY |
| 5 Welded Joints (1 hour)                       |
| Fitting Time (10 minutes)                      |

To find your nearest Velan Steam Trap distributor, please email:  
[sales@velansteamtraps.com](mailto:sales@velansteamtraps.com) or call 1-800-860-0233

To learn more about Velan steam traps, visit us at  
[www.velansteamtraps.com](http://www.velansteamtraps.com)